

## DC Outputs

Two-, three-, or four-wire proximity sensors contain a transistor oscillator and a snap-action amplifier. This provides exceedingly high accuracy to a set switching point, even with very slowly approaching targets. Switching characteristics are unaffected by supply voltage fluctuations within the specified limits.

The sensors can drive electromechanical relays, counters, solenoids, or electronic modules, and interface directly with logic systems or programmable controllers without additional interface circuitry. They are available with either NPN output transistors (current sinking) or PNP output transistors (current sourcing).

Load current ratings vary from 100 mA to 200 mA depending on physical size. Standard voltage range is 10-30 VDC with certain types available for 10-65 VDC. All models incorporate wire-break, transient and reverse polarity protection.

Power-On false pulse suppression is also standard.

## Short-Circuit and Overload Protection

TURCK DC sensors with a Voltage Range designation of "4", "6" or "8" in the part number are short-circuit and overload protected (automatic reset). These sensors incorporate a specially designed circuit which continuously monitors the ON state output current for a short-circuit or overload condition. If either of these fault conditions occurs, the output is turned OFF and pulse tested until the fault is removed. This added protection causes a  $\leq 1.8$  V drop across the output in the normal ON state. This may be a problem when interfacing with some logic low inputs (see TTL compatibility).

## TTL Compatibility

Some solid-state loads requiring NPN (sinking) input signals need a  $\leq 0.8$  V signal to reliably turn ON. **TURCK** DC sensors with TTL compatibility are designated with the voltage range "7" in the part number. The output of these sensors will have a voltage drop of  $\leq 0.7$  V (0.3 V typical), which will ensure reliable operation. Do not use voltage ranges "4" and "6" when TTL compatibility is required.

**Figure 1**

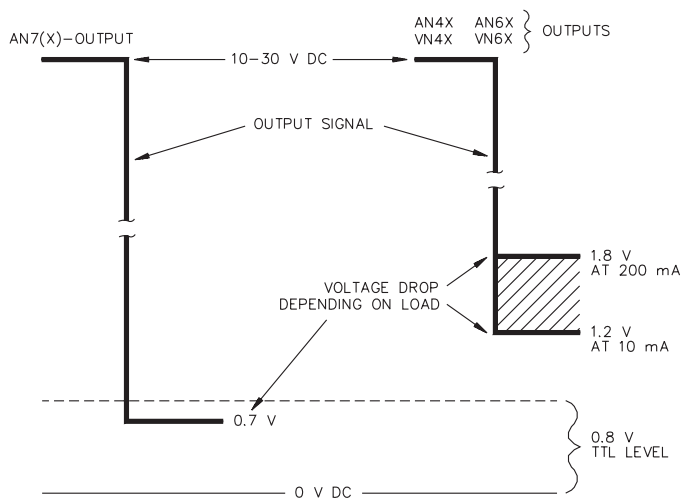

**Figure 2**

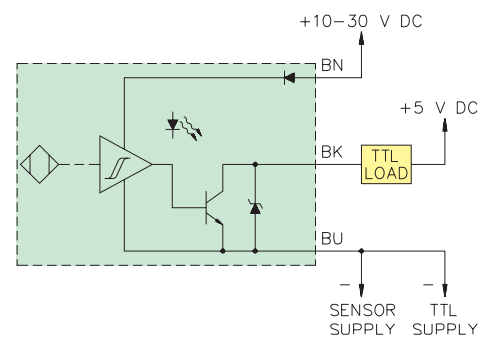

Voltage drop is measured from output wire black (BK) to ground wire blue (BU).

## DC Sourcing and Sinking

### 2-Wire DC

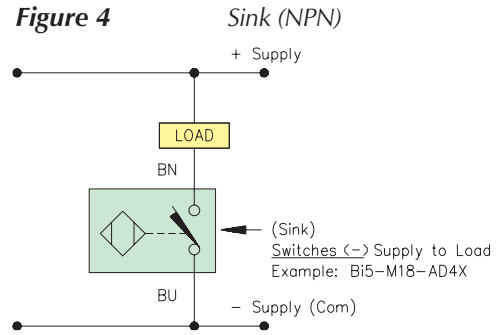
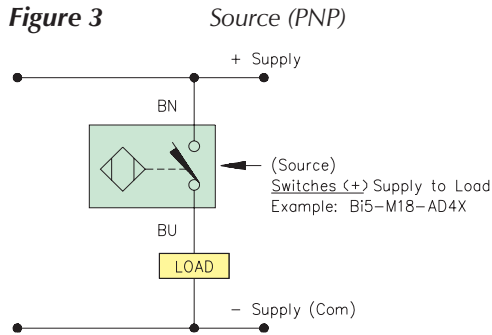

Note: TURCK 2-wire DC sensors with an "AD" designation are not polarity sensitive and can be used to sink or source a load.

### 3-Wire DC

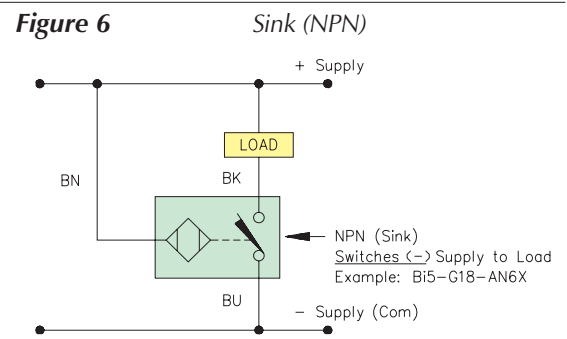
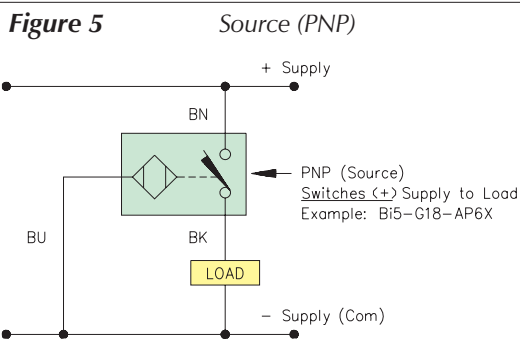

## DC Outputs

### "AD" 2-Wire DC Output

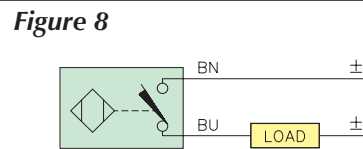
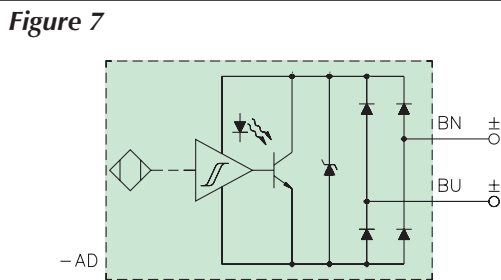

### "AG" 2-Wire DC Output

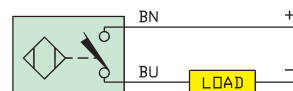
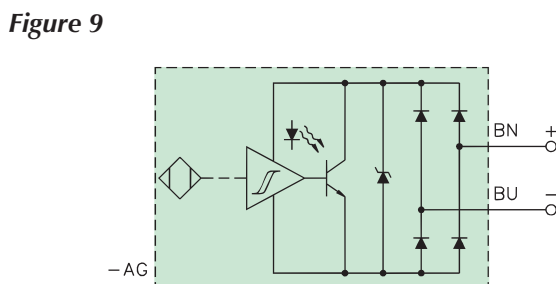

**DC Outputs**

**"AN4" and "AP4" 3-Wire DC Outputs**

**Figure 10 Electronic Output Circuit**

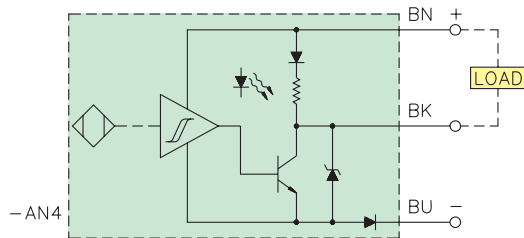

**Figure 11 Wiring Diagram**

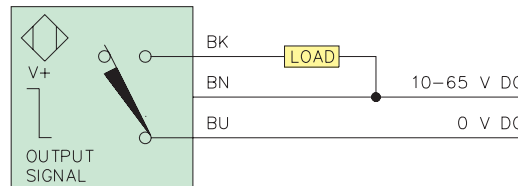

NPN transistor  
 (i.e. current sinking  
 negative switching)  
 N.O. output

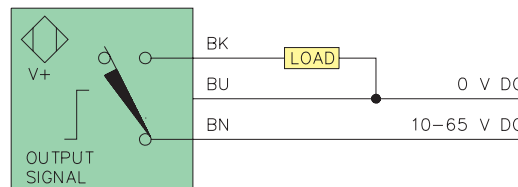
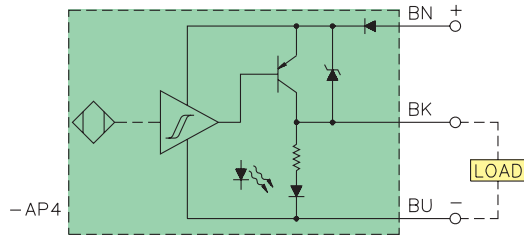

PNP transistor  
 (i.e. current sourcing  
 positive switching)  
 N.O. output

**"AP6" 3-Wire DC Outputs**

**Figure 12 Electronic Output Circuit**

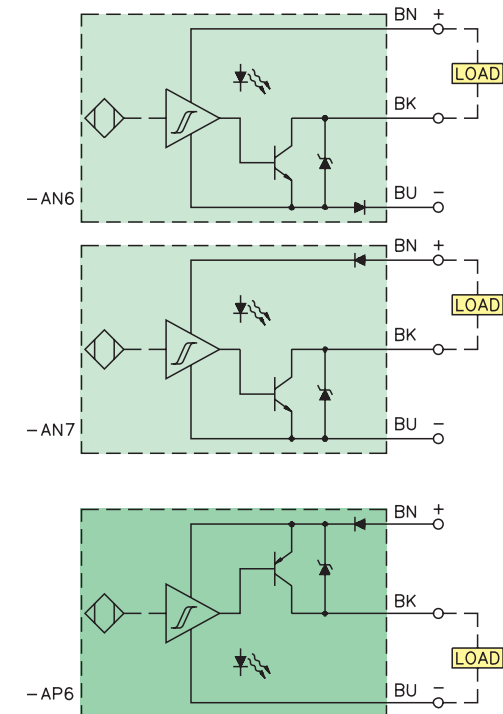

**Figure 13 Wiring Diagram**

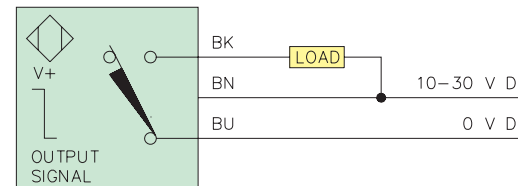

NPN transistor  
 (i.e. current sinking  
 negative switching)  
 N.O. output

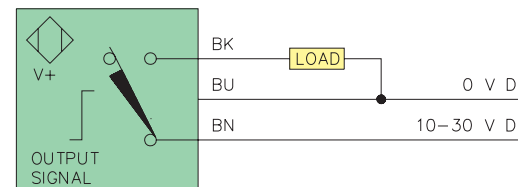

PNP transistor  
 (i.e. current sourcing  
 positive switching)  
 N.O. output

**"AN6(7)" and**

**TURCK TIP**

- Order current sinking (NPN) sensors with the voltage range "7" only when low voltage drop for TTL gates is required. In all other cases, order sensors with voltage ranges "4" or "6".

DC Outputs

Specs

"VN4" and "VP4" 4-Wire DC Outputs

Figure 14 Electronic Output Circuit

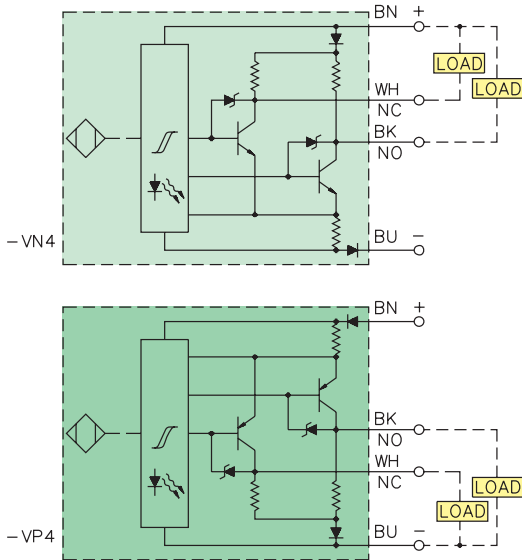
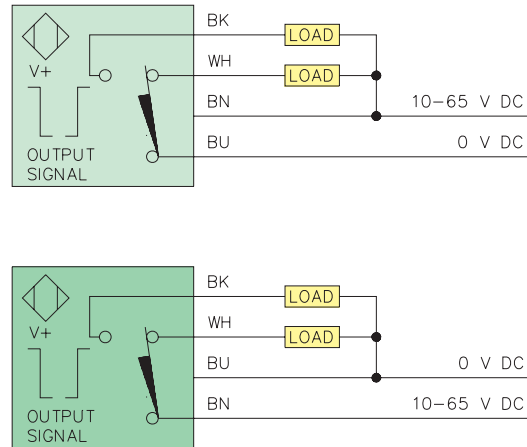

Figure 15 Wiring Diagram



NPN transistor (i.e. current sinking negative switching) complementary output (SPDT)

PNP transistor (i.e. current sourcing positive switching) complementary output (SPDT)

"VN6" and "VP6" 4-Wire DC Outputs

Figure 16 Electronic Output Circuit

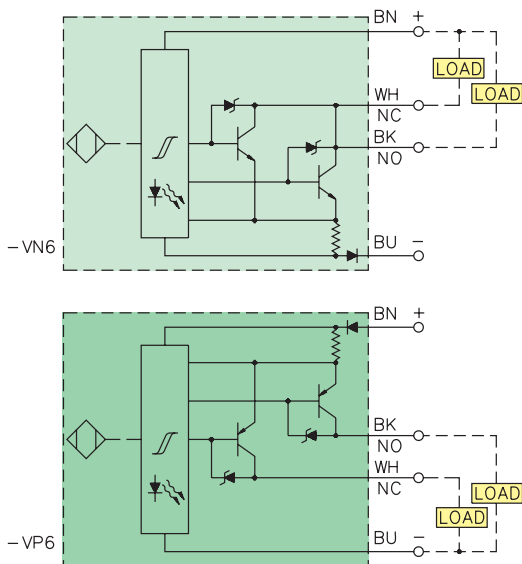
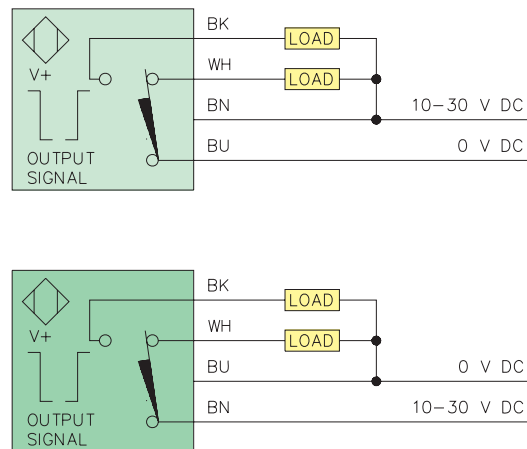

Figure 17 Wiring Diagram



NPN transistor (i.e. current sinking negative switching) complementary output (SPDT)

PNP transistor (i.e. current sourcing positive switching) complementary output (SPDT)

**DC Outputs**

**"LIU" 4-Wire Linear Analog DC Output**

**Figure 18** *Electronic Output Circuit*

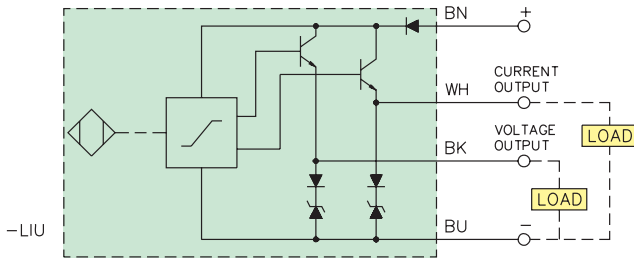

**Figure 20** *Wiring Diagram*

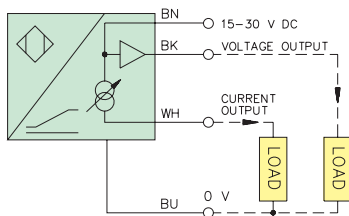

**Figure 19** *Typical Response Curve*

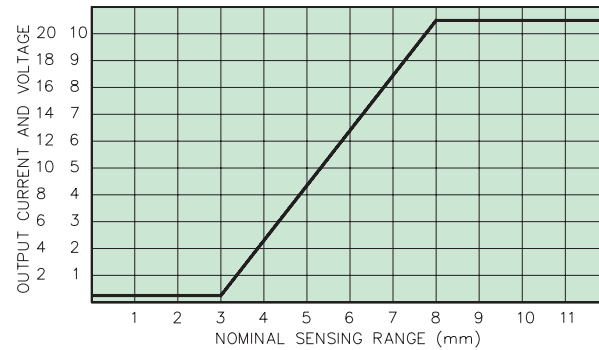

Linear Analog Output; Current and Voltage

**Series/Parallel Connection**

**Logic functions with DC proximity sensors:**

Self-contained proximity sensors can be wired in series or parallel to perform such logic functions as AND, OR, NAND, NOR. The wiring diagrams show the hook-up of four sensors with NPN and PNP outputs.

Take into account the accumulated no-load current and voltage drop per sensor added in the series string.

**Series-connection:**

- N.O. sensors: AND Function  
 (target present, all sensors: load "on")
- N.C. sensors: NOR Function  
 (target present, any sensor: load "off")

**Parallel-connection:**

- N.O. sensors: OR Function  
 (target present, any sensor: load "on")
- N.C. sensors: NAND Function  
 (target present, all sensors: load "off")

**TURCK TIP**

- To prevent the load from seeing the cumulative voltage drop of multiple 3-wire sensors in series, alternating polarity sensors can be used provided that the desired polarity is at the load.
- Wiring 3-wire sensors in series delays the load by the accumulated "time delay before availability" of all sensors in the string.

**Series/Parallel Connection**

**Figure 21 NPN Connection**

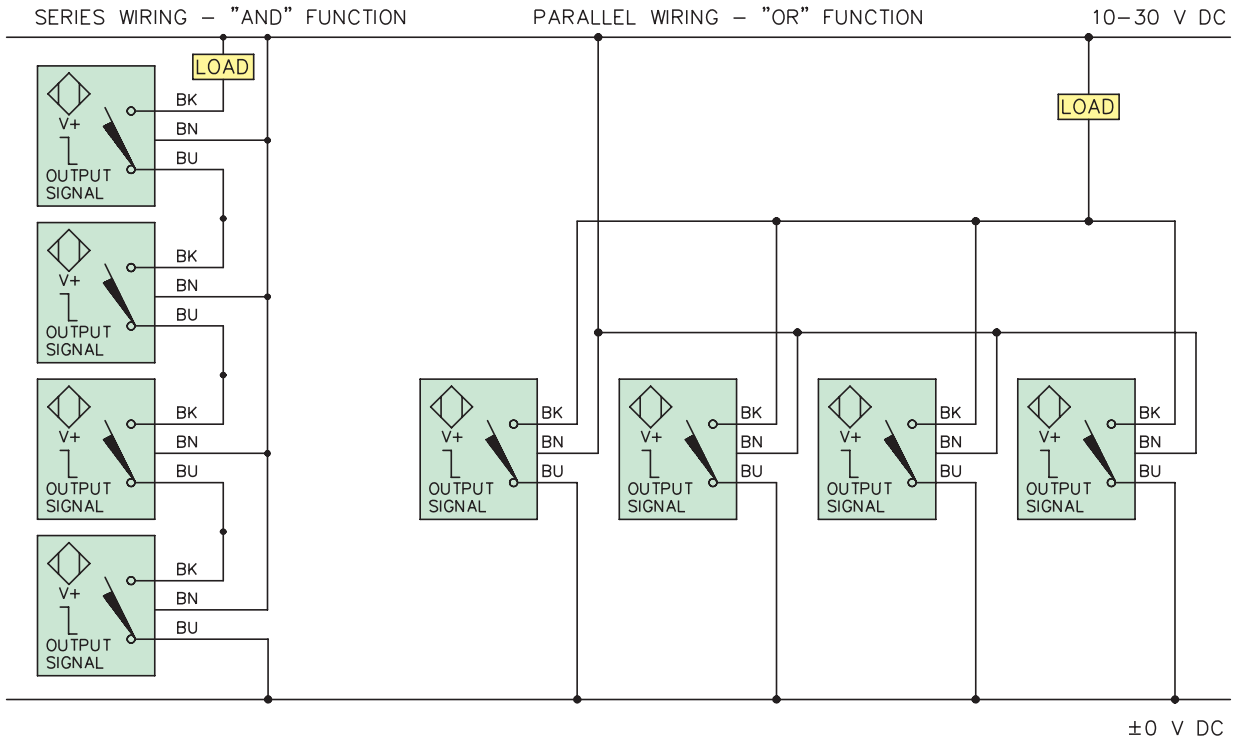

**Figure 22 PNP Connection**

