

AS-i 3.0 PROFIBUS Gateway with integrated Safety Monitor

2 AS-i 3.0 Master, PROFIBUS-Slave

- Redundant power supply out of AS-i:
all fundamental functions of the device remain available even in case of power failure in one of the two AS-i networks
- Full functional range
of Bihl+Wiedemann PROFIBUS Gateway BWU1568!
- Enhanced functional range
of Bihl+Wiedemann Safety Monitor BWU2000!
- Compatible with the wide range of
Bihl+Wiedemann power supplies

1 AS-i Safety Monitor in Stainless Steel for 2 AS-i networks

- Operation using a single Monitor configuration
Monitor processes safety slaves on two AS-i networks
Coupling between the two networks superfluous

16 release circuits

- 4 CAT4, SIL 3 safe output circuits on the Monitor
two sets of safe relays
two sets of fast electronic safe outputs

Safe AS-i outputs are supported on both AS-i networks

- 16 independent AS-i outputs
Multiple safe AS-i outputs possible via a single AS-i address

Monitor configuration can be „arbitrarily“ large

- 256 configuration blocks (previously 48)
Identical reaction time due to artificial limitation to 256 configuration blocks

Chip card for storage of configuration data



Article no.	BWU2001
PROFIBUS interface	according to DIN 19 245, part 3
Baud rates	9,6 kBaud up to 12 000 kBaud, automatic recognition
DP functions	imaging of the AS-i slaves as I/O data of the PROFIBUS complete diagnosis and configuration via the PROFIBUS DP
Serial interface	RS 232
AS-i cycle time	150 µs · (number of slaves + 2)
Safety monitor	
Release circuits	4
Start delay	< 10 s
Respond delay	< 40 ms
Inputs: 4 x EDM/Start	EDM: inputs to monitor external devices Start: Start inputs switching current statical 4 mA at 24 V, dynamic 30 mA at 24 V (T=100 µs)
Outputs: 4 x output switching elements	relay outputs (output circuits 1 and 2) max. contact load: 3 A AC-15 at 30 V, 3 A DC-13 at 30 V semiconductor outputs (output circuits 3 and 4) max. contact load: 0,5 A DC-13 at 30 V
Card slot	chip card for storage of configuration data
Displays	
LCD	indication of slave addresses and error messages
LED power	power on
LED PROFIBUS	PROFIBUS master recognized
LED config error	configuration error
LED U AS-i	AS-i voltage OK
LED AS-i active	AS-i normal operation active
LED prg enable	automatic addresses programming enabled
LED prj mode	configuration mode active
LED AUX	auxiliary power
4 x LED EDM/Start	state of inputs: LED off: open LED on: closed

AS-i 3.0 PROFIBUS Gateway with integrated Safety Monitor

Article no.	BWU2001
4 x LED output circuit	state of output circuits: <i>LED off: open</i> <i>LED on: closed</i>
Electrical data	
Operating current	master power supply, max. 300 mA out of AS-i circuit 1 (approx. 70 mA ... 300 mA), max. 300 mA out of AS-i circuit 2 (approx. 70 mA ... 300 mA); in sum max. 370 mA
Operating voltage	30 V, 9 W
Voltage of insulation	≥ 500 V
UL-specifications (UL508)	
External Protection	An isolated source with a secondary open circuit voltage of $\leq 30 V_{DC}$ with a 3 A maximum over current protection. Over current protection is not required when a Class 2 source is employed.
in general	UL mark does not provide UL certification for any functional safety rating or aspects of the above devices.
cTÜVus	The devices BWU2001 from Bihl + Wiedemann GmbH were safety certified by TÜV Rheinland of North America, Inc. according to UL-standards and meet the safety requirements for the North American market.
Standards	EN 61 000-6-2 EN 61 000-6-4 EN 62 061:2005, SILCL 3 EN 61 508:2001, SIL 3 EN ISO 13 849-1:2008, PL e
Housing	AS-i master housing in stainless steel
Ambient operating temperature	0°C ... +55°C
Storage temperature	-25°C ... +85°C
Dimensions (L / W / H in mm)	120 / 100 / 96
Protection category IEC 60 529	IP20
Tolerable loading referring to impacts and vibrations	according to EN 61 131-2
Weight	800 g

Safety Monitor block diagram:

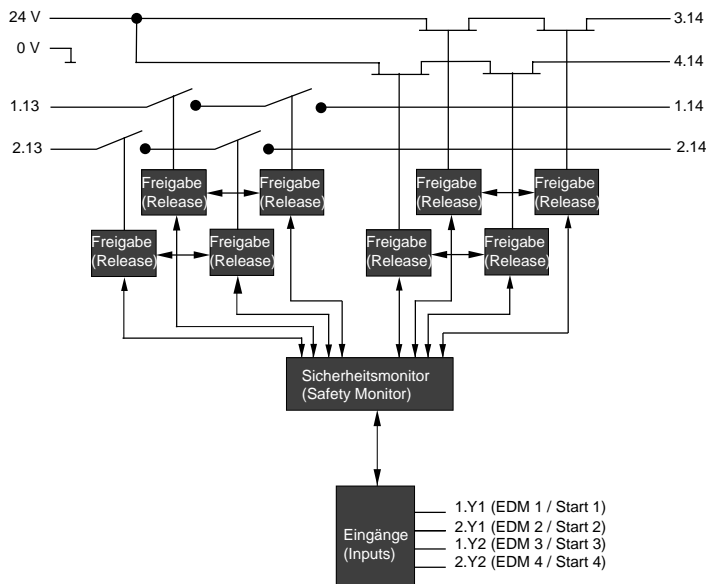

Connections:

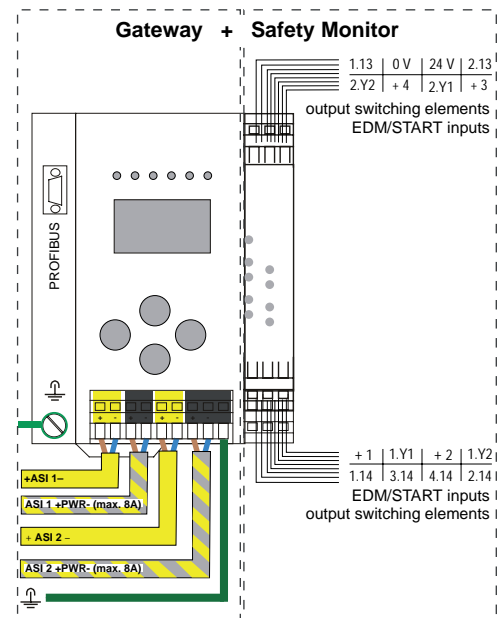

Accessories:

- Software ASIMON 3 G2 and AS-i Control-Tools with serial cable for AS-i Master/monitors in stainless steel (art. no. BW2071)
- Serial PROFIBUS-Master (art. no. BW1258)
- PROFIBUS-DP-Master simulator (art. no. BW1257)