

- threaded barrel, M12 x 1
- long version
- Chrome-plated brass
- factor 1 for all metals
- magnetic field immune
- extended temperature range
- high switching frequency
- 4-wire DC, 10...65 VDC
- change-over, npn output
- connector, M12 x 1

**Wiring diagram**

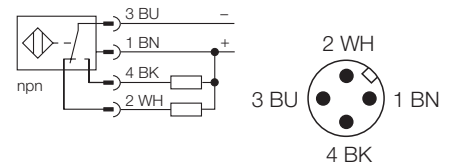

**Functional principle**

Inductive sensors are designed for wear-free and non-contact detection of metal objects. Due to a ferrite-less 3-coil system, uprox factor 1 sensors have distinct advantages. They detect all metals at the same switching distance, are magnetic field immune and feature large switching distances.

<b>Type</b>	Ni8U-M12E-VN4X-H1141
Ident-No.	1580552
<b>Rated operating distance Sn</b>	8 mm
Mounting condition	non-flush
Assured sensing range	≤ (0,81 x Sn) mm
Repeatability	≤ 2 %
Temperature drift	≤ ± 10 %
Hysteresis	≤ ± 15 %, ≤ -25 °C v ≥ +70 °C
Ambient temperature	-30... + 85 °C
<b>Operating voltage</b>	10... 65VDC
Residual ripple	≤ 10 % U <sub>ss</sub>
DC rated operational current	≤ 200 mA
No-load current I <sub>0</sub>	≤ 15 mA
Residual current	≤ 0.1 mA
Rated insulation voltage	≤ 0.5 kV
Short-circuit protection	yes / cyclic
Voltage drop at I <sub>e</sub>	≤ 1.8V
Wire breakage / Reverse polarity protection	yes / complete
Output function	4-wire, change-over, npn
Insulation class	□
Switching frequency	≤ 2 kHz
<b>Housing</b>	threaded barrel, M12 x 1
Dimensions	62 mm
Housing material	metal, CuZn, chrome-plated
Material active face	plastic, PBT
Tightening torque of housing nut	10 Nm
Connection	connectors, M12 x 1
Vibration resistance	55 Hz (1 mm)
Shock resistance	30g (11 ms)
Degree of protection	IP67
<b>Display switch state</b>	LED yellow

---

<b>Mounting instructions</b>	minimum distances
Distance D	3 x B
Distance W	3 x Sn
Distance T	4 x B
Distance S	1,5 x B
Distance G	6 x Sn
Distance N	2 x Sn

---

<b>Diameter of the active area B</b>	Ø 12 mm
--------------------------------------	---------

---

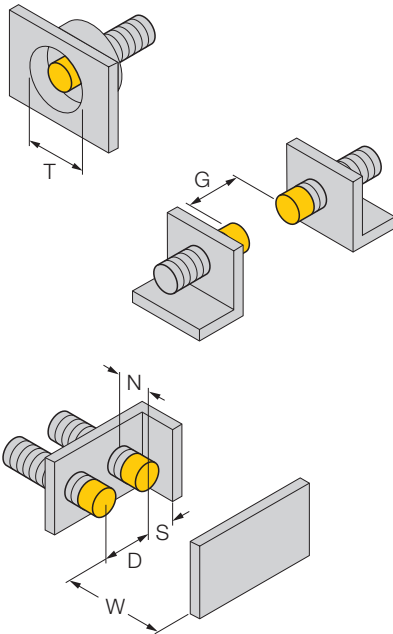

**Accessories**

Type code	Ident-No.	Short text	Dimension drawing
BST-12B	6947212	fixing clamp with dead-stop; material: PA6	
QM-12	6945101	quick-mount fixing clamp with dead-stop; material: chrome-plated brass male thread M16 x 1. Note: The switching distance of proximity switches can be reduced by the use of quick mounting brackets.	
MW-12	6945003	mounting bracket; material: stainless steel A2 1.4301 (AISI 304)	
BSS-12	6901321	fixing clamp; material: polypropylene	