

WIRING DIAGRAMS

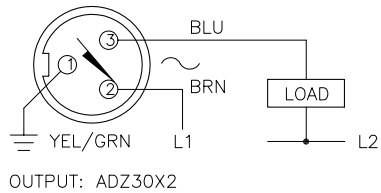

SHORT-CIRCUIT AND OVERLOAD PROTECTED

LOCKNUT LN-MT30

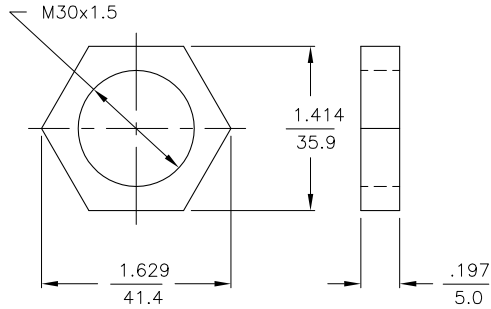

SPECIFICATIONS

OPERATING VOLTAGE	20-250 VAC 10-300 VDC
LINE FREQUENCY	40-60 Hz
HYSTERESIS	3-15%
VOLTAGE DROP ACROSS CONDUCTING SENSOR	≤6.0 V at 400 mA
OUTPUT FUNCTION	NORMALLY OPEN 2-WIRE AC/DC SELF-CONTAINED
SHORT-CIRCUIT PROTECTED	YES
TRIGGER CURRENT FOR OVERLOAD PROTECTION	≥440 mA
CONTINUOUS LOAD CURRENT	400 mA AC 300 mA DC
RESIDUAL CURRENT	≤1.7 mA
MINIMUM LOAD CURRENT	≥3.0 mA
INRUSH CURRENT	≤4.0 A (≤20 ms/5 Hz)
TIME DELAY BEFORE AVAILABILITY	≤120 ms
POWER-ON EFFECT PROTECTION	INCORPORATED
PROTECTION AGAINST TRANSIENTS	YES
OPERATING TEMPERATURE	-25°C to +70°C (±10% DRIFT) -30°C to +85°C (±15% DRIFT)
ENCLOSURE	MEETS NEMA 1, 3, 4, 6, 13 AND IEC IP 67
SHOCK	30 g, 11 ms
VIBRATION	55 Hz, 1 mm AMPLITUDE (IN ALL 3 PLANES)
LED FUNCTION	GREEN = POWER ON GREEN FLASHING = SHORT-CIRCUIT WARNING YELLOW = OUTPUT ENERGIZED
RATED OPERATING DISTANCE	20 mm = .787"
SWITCHING FREQUENCY	20 Hz
REPEATABILITY	≤2% OF RATED OPERATING DISTANCE
EMBEDDABLE (SHIELDED)	NO

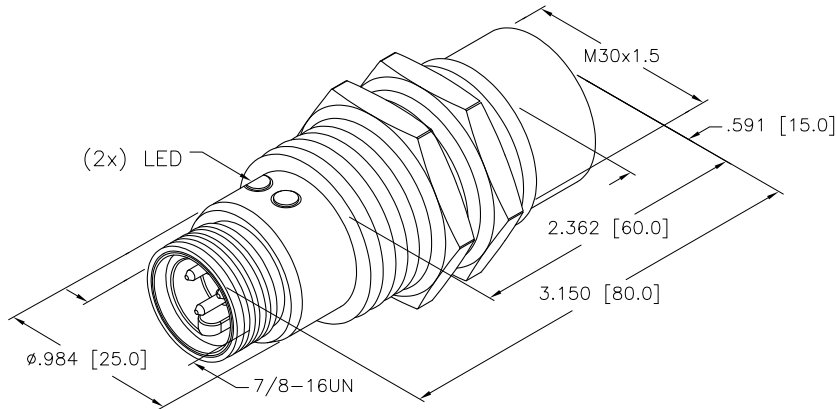

NOTES:

- WELD FIELD IMMUNE. SENSORS IS SUITABLE FOR USE ON RESISTANCE WELDING MACHINES.
- MATERIALS:
TEFLON-COATED BRASS BARREL.
CHROME-PLATED BRASS CONNECTOR.
TEFLON-COATED BRASS LOCKNUTS.
SILVER-CHROMATED STEEL LOCKWASHERS.
TEFLON-COATED PA 12-GF30 PLASTIC SENSING FACE.

RELATED DOCUMENTS 1. 2. 3. 4.	3RD ANGLE PROJECTION 	THIS DRAWING IS PROPERTY OF TURCK INC. USE OF THIS DOCUMENT WITHOUT WRITTEN PERMISSION IS PROHIBITED.		3000 CAMPUS DRIVE MINNEAPOLIS, MN 55441 1-800-544-7769 (763) 553-7300 (763) 553-0708 fax turck.com	
	MATERIAL BRASS BARREL	DRFT IK	DATE 12-30-96	DESCRIPTION Ni20U-GT30-ADZ30X2-B1131	
FINISH COPPER/NICKEL/ CHROME PLATING	ALL DIMENSIONS DISPLAYED ON THIS DRAWING ARE FOR REFERENCE ONLY	DGSN	SCALE 1=1.3	IDENTIFICATION NO. M4281822	
CONTACT TURCK FOR MORE INFORMATION		UNIT OF MEASUREMENT INCH [MILLIMETER]		REV B	
DO NOT SCALE THIS DRAWING		FILE: M4281822		SHEET 1 OF 1	

B	UPDATE BARREL LENGTH	RDS	06/15/11	35386
REV	DESCRIPTION	BY	DATE	ECO NO.